

15kW_{60Hz} 12.5kVA_{50Hz}

norpro

A Global Power Solutions Company

Power Max Series

I/EJ/FG

15PMY

Standby Rating 60Hz: 15kW

Prime Rating 60Hz: 13.5kW

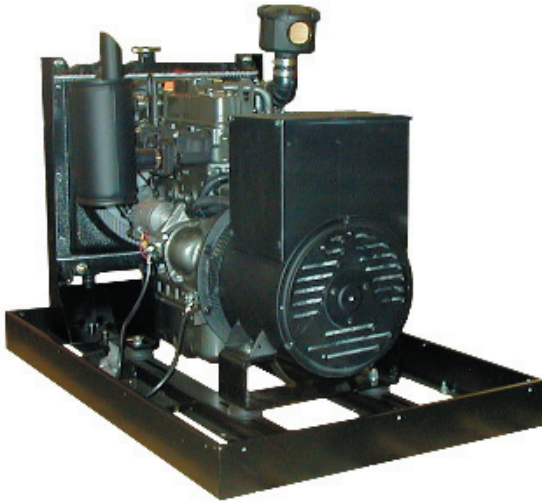

Philosophy at Norpro

- Build a reliable product for the harshest of operating environments.
- Supply a product which is simple to operate and easy to maintain
- Use the best technology and materials available
- Provide the best value in the industry

More For Your Money

Norpro has been a leader in generator technology since we began operations in 1986. We strive to provide the best in terms of durability, performance, and value in the generator market. Using only world-class engines and components, we hand build the highest quality generators possible. By using high grade materials including, epoxy paint, stainless hardware, and powder coat, you can rest assured your generator will look good for many years to come. Our sound shields were developed using input from the aerospace industry. The results speak quietly on their own with sound canceling effects decreasing noise on average by 50%. We are very committed and proud of our product which is why we offer one of the most extensive warranties available. With the support of an experienced warranty representative, and a multi-million dollar inventory, all your generator needs are just a phone call away. Sales and services are handled by factory trained distributors and dealers reaching across the country and around the world. Everything is done to help us meet your needs and exceed your expectations.

Standard Features

- Radiator Cooled Genset
- Muffler
- Air Filter
- Steel Skid Base
- Rubber Isolation Mounts
- Battery Tray
- Battery Cables and Hold Down
- Battery Charger (3 amp)
- Oil Drain Kit
- Digitec 300 Control Panel
- ABS Molded Fan Guard
- Hand Built in the USA
- Prototype and Production Tested
- Meets or Exceeds Tier 4 Nonroad Emissions Regulations
- 5 Year 5,000 Hour Warranty

Digitec 300 Controller

- Programmable microprocessor panel
- Engine start up with an automatic preheat system
- Digital display
 - water temperature
 - oil pressure
 - tamper proof hour meter
 - battery voltage
- Safety systems
 - automatic shutdown for low oil pressure
 - high water temperature
 - over speed
 - over frequency
- Three onboard replaceable 40AMP fuses for fuel, crank, and timer outputs
- 5.5" x 4.3" x 2.16" (L x H x D)
- Conforms to 12V or 24V operations!



Complete details

also available on our
website.

Please visit:

www.4norpro.com

Engine Specifications	60Hz	50Hz
Manufacturer	Yanmar	
Engine model	3TNV88	
Cylinder arrangement	3 in line 4-cycle	
Displacement, cu.in. (cc)	100.2 (1642)	
Bore and stroke, (in.)	3.46 x 3.54	
Compression ratio	19.1:1	
Rated rpm	1800	1500
Max power at rated rpm (bhp)	21.7	18.1
Cylinder head material	Cast Iron	
Block material	Cast Iron	
Governor type	Mechanical	
Frequency regulation	3-5%	
Air cleaner type	Replaceable Element	

Engine Electrical System

Ignition system	Electric	
Battery charging system voltage (DC)	12V	
Battery charging system (amps)	40	
Starter system voltage (DC)	12V	
Battery recommendation (CCA)	500	
Battery voltage (DC)	12V	
Starter kW	1.2	

Generator Specifications

Type	4 Pole	
Exciter type	Brushless	
Leads: Quantity	4	
Voltage regulator	AVR	
Insulation material	H type	
Temperature rise	105° C	
Bearing type	Sealed	
Coupling	Direct bolt-up	
Voltage regulation	1%	
Phase type	1	
Power factor	1.0	
Power rating kW (kVA)	15 (15)	12.5 (12.5)
Mainline breaker (amps) optional	50	40

Generator Ratings

Amps @ 120	120	104
Amps @ 240	62.5	52

Weights and Dimensions

	Length in. (cm)	Height in. (cm)	Width in. (cm)	Dry Weight lbs. (kg)	Wet Weight lbs. (kg)
Open Unit	45.5 (116)	31.0 (78.7)	30.0 (76)	640 (290.3)	657 (298)
Enclosed	46.0 (117)	33.0 (83.8)	30.5 (77.5)	690 (313)	707 (320.7)
Open w/Sub. Tank	46.0 (117)	42.0 (106.7)	30.5 (77.5)		

Stand Alone Fuel Tanks

165 gal./620L	29 (74)	61 (155)	28 (72)	132 (60)	1287 (584)
275 gal./1000L	51 (130)	54 (137)	30 (76)	208 (94)	2133 (968)

Lubrication System	60Hz	50Hz
Type	Full Pressure	
Engine oil capacity w/filter, qt.(L)	7.08 (6.7)	
Oil filter type	Spin-on	

Fuel System

Fuel shutoff solenoid	Electric	
Fuel pump	Mechanical	
Fuel pump priming	Electric	
Fuel type	ULS Diesel	
Fuel pump lift, ft (m)	3.28 (1)	
Fuel line supply	5/16	
Fuel line return	5/16	

Cooling System

Engine coolant capacity, qt.(L)	2.11 (2)	
Radiator coolant capacity, qt.(L)	3.5 (3.3)	
Water pump type	Centrifugal	
Fan diameter, in.(cm)	15 (38.1)	
Fan & Alternator (hp)	1	
Fan type	5 Blade Pusher	
Fan rotation from front of engine	Clockwise	

Air Requirements

Engine combustion air intake (CFM)	46.9	
Generator end cooling (CFM)	220	
Sound shield air space, in. (cm)	18 (46)	

Exhaust System

Exhaust type	Residential Muffler	
Max allowable back pressure (in.hg)	3.77	
Exhaust outlet size, in.(cm)	1.5 (3.81)	

Fuel Consumption

100% Load, gph (lph)	1.25 (4.7)	1.04 (3.91)
75% Load, gph (lph)	1.05 (4.0)	.87 (3.33)
50% Load, gph (lph)	.75 (2.8)	.62 (2.33)

Sound Tables

dB(A) Without Sound Shield

Load	100%	75%	50%
3'	86	85	85
10'	83	83	82
21'	80	79	77

dB(A) With Sound Shield

Load	100%	75%	50%
3'	72	73	72
10'	70	68	67
21'	68	66	65

OPTIONAL EQUIPMENT

Analog 200 Control Panel

- Three gauge panel
- Water temperature, oil pressure, battery voltage
- Hour meter and preheat display
- Ten second oil pressure bypass timer
- Emergency shutdowns for high water temp and low oil pressure
- 12-volt breaker protection
- 6.75" x 5.5" x 4.25" (L x H x D)
- Black over white ABS faceplate

Remote Start Panel

- Starting and stopping capabilities from a remote location
- Start/Stop switch
- Unit hourmeter
- 3"H x 6"L ABS plate
- Includes "Y" harness

Digitec 400 Controller

Includes all features on the Digitec 300

- Most vivid LCD screen available
- Automatic battery recharge
- Real time clock
- Eight digital programmable inputs
- Twenty-five programmable digital outputs
- Automatic shutdown for any discrepancy in:
 - current
 - speed
 - voltage
 - frequency
 - battery levels
- Password protected
- Fully programmable engine exerciser
- 100 event failure log
- Connection for six industry standard analog senders
- Sleep mode to conserve battery
- 5.47" x 4.45" x 2.56" (L x H x D)

Color Options

- Bonsai Blue
- Zodiac Blue
- Midnight Black
- Anthracite Gray
- Soft Silver

Remote Extension Cables

- Mount your panel virtually anywhere
- Eight or twelve pin rubber molded connectors
- Extension harness, 5' (1.5 m)
- Extension harness, 10' (3 m)
- Extension harness, 20' (6 m)
- Extension harness, 50' (15.2 m)

Fuel Tanks

- Sub-base mounted, UL Listed, double wall tank
- Stand alone, UL Listed, double wall tank, 165 gal. (620 L)
- Stand alone, UL Listed, double wall tank, 275 gal. (1000 L)

Dual Station Instrumentation

- Analog panel system
 - Full instrumentation at two locations
 - Start and stop capability

Enclosures

- Protects from the elements and animal intrusions
- Decrease noise while maintaining airflow
- All aluminum (stainless steel hardware)
- 5052 .080 aluminum
- Powder coated to ensure a long lasting finish
- Complete teardown in minutes using only a # 2 philips screwdriver
- Doors come off/open via durable Southco latches
- Sophisticated polyether foam adds further sound deadening on sound enclosures
- Foam is UL 94 HF1 listed for flammability testing

More Options

- Battery
- Critical muffler kit
- 24V kit
- D.O.T. trailer
- Interlocking mounts
- Manual transfer switch
- Automatic transfer switch
- Mainline breaker
- Inline style block heater
- Cartridge type air filter
- Electronic governing
- "Y" harness

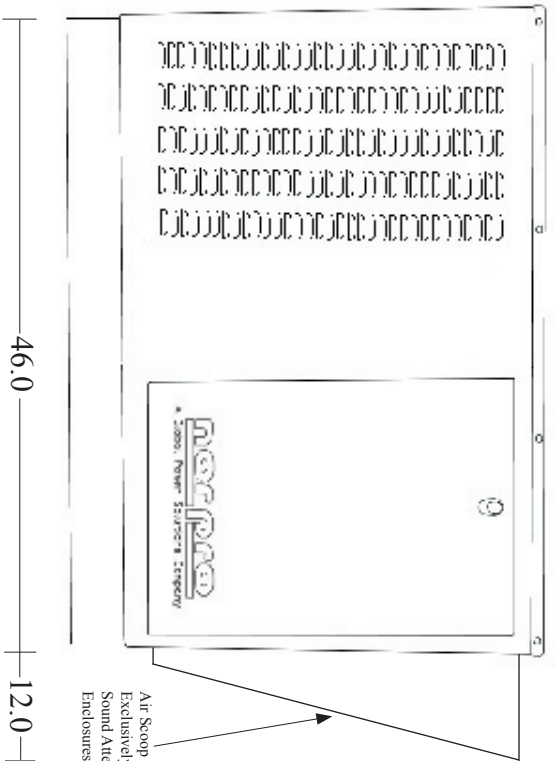
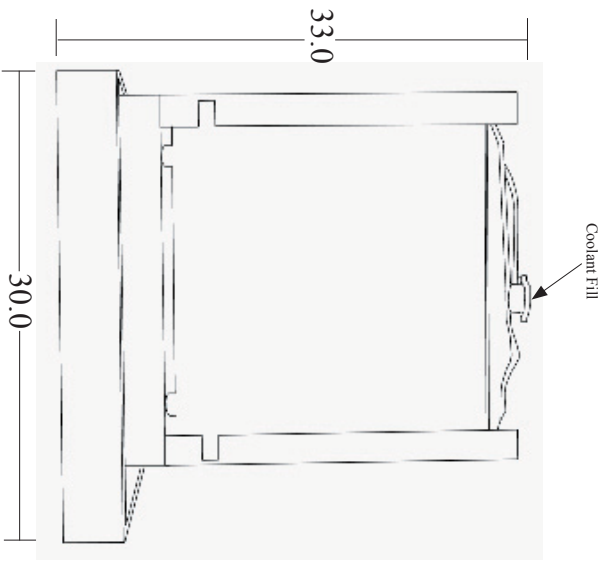
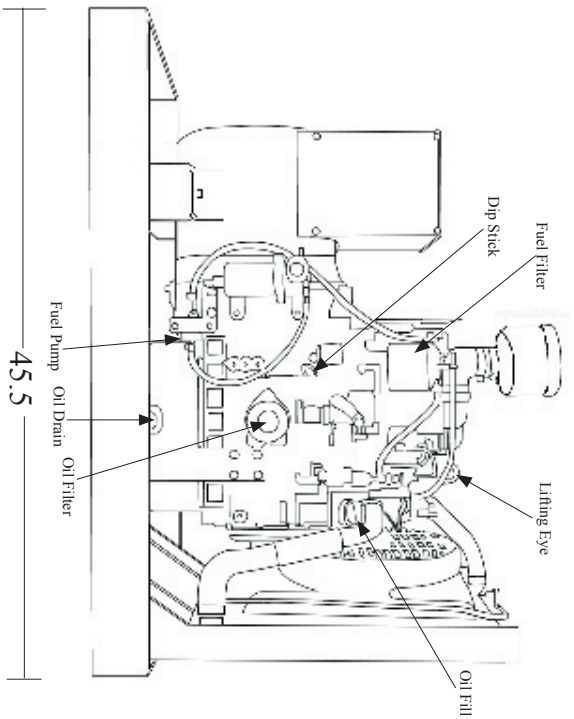

Air Scoop Featured Exclusively on Sound Attenuating Enclosures

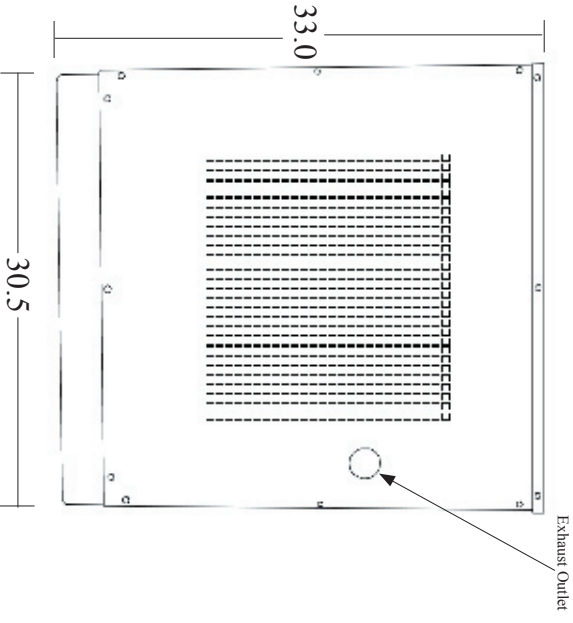

Exhaust Outlet



Plant address: 85 : U'gf'XZAccXI g, CT 064* - Tel:(860) 873-0100
 Fax:(860) 873-0200 TOLL FREE 1-877-4NORPRO www.4norpro.com

Model - 15PMY
Distributed by: